

OXYFLEX® - MS70 MEMBRAN-TUBE-DIFFUSER

for fine- and coarse bubble aeration of fluids

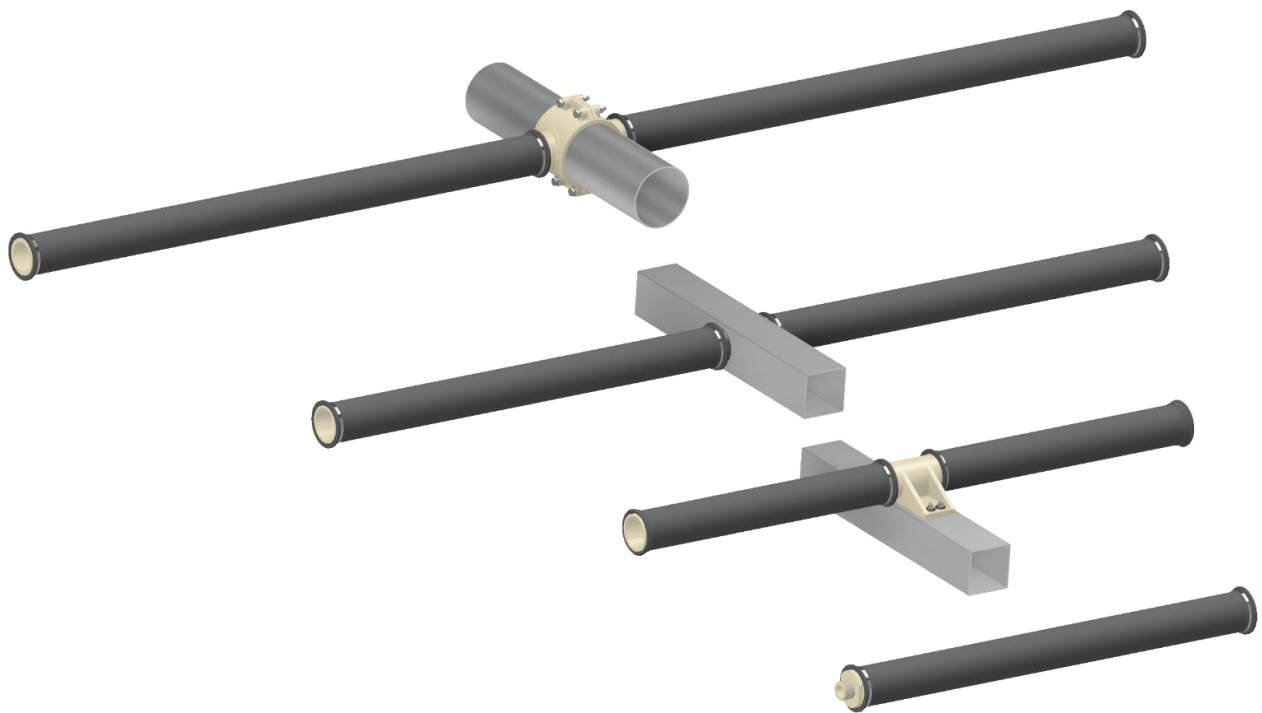

Supratec

GESELLSCHAFT FÜR UMWELT-
UND VERFAHRENSTECHNIK MBH

Von-Drais-Straße 7
D-55469 Simmern / Hunsrück

phone.: 06761 / 9 65 09 - 00

Email: info@oxyflex.de

Website: www.oxyflex.de



OXYFLEX® – MS70 Membrane-Tube-Diffuser

The Membrane-Tube-Diffuser OXYFLEX® - MS70 consists out of a Ø°63mm carrier pipe (polypropylene) with a diffuser membrane. Suitable for project-specific aeration pipes different mounting solution are available for our membrane tube diffuser.

The fine and coarse bubble diffuser membranes, available as EPDM- (ethylen-propylenediene-monomer rubber) or PUR- (polyurethane) membrane, are fixed by stainless steel clamps (AISI304 as standard / AISI316 optional available) on the carrier pipe.

The OXYFLEX® - MS70 is predominantly used for oxygen supply in biological waste water treatment plants. At optimal conditions specific oxygen inputs of up to 25 gO₂/(Nm³ x m) can be realized. The fine bubble diffuser feed is recommended between 2 – 8 Nm³/h per meter diffuser length (please compare also table 1).

The body is completely floodable to reduce the buoyancy.

The OXYFLEX® - MS70 is characterised by following features:

- ▶ Mounting solutions for round and square pipes in stainless steel and plastic
- ▶ Available in different lengths
- ▶ Unsusceptibility against pollution

The OXYFLEX® - MS70 is available in three standard lengths:

- ▶ OXYFLEX® - MS70 1.0 – with a length of 2 x 500 mm, Ø 70mm
- ▶ OXYFLEX® - MS70 1.5 – with a length of 2 x 750 mm, Ø 70mm
- ▶ OXYFLEX® - MS70 2.0 – with a length of 2 x 1000 mm, Ø 70mm

Upon request the lengths can optionally be projectspecifically customized.

As an alternative to the fine bubble aeration, the membranes could also be manufactured as a coarse bubble version.

The following diagram shows exemplarily the result of an oxygen transfer test. The values were measured in a square tank with a water depth of 5,75 m, a diffuser blow-in depth of 5,45 m and a diffuser density of 10,8%.

Specific standard oxygen transfer SSOTR and pressure loss of the OXYFLEX® - MS70 Membrane-Tube-Diffuser

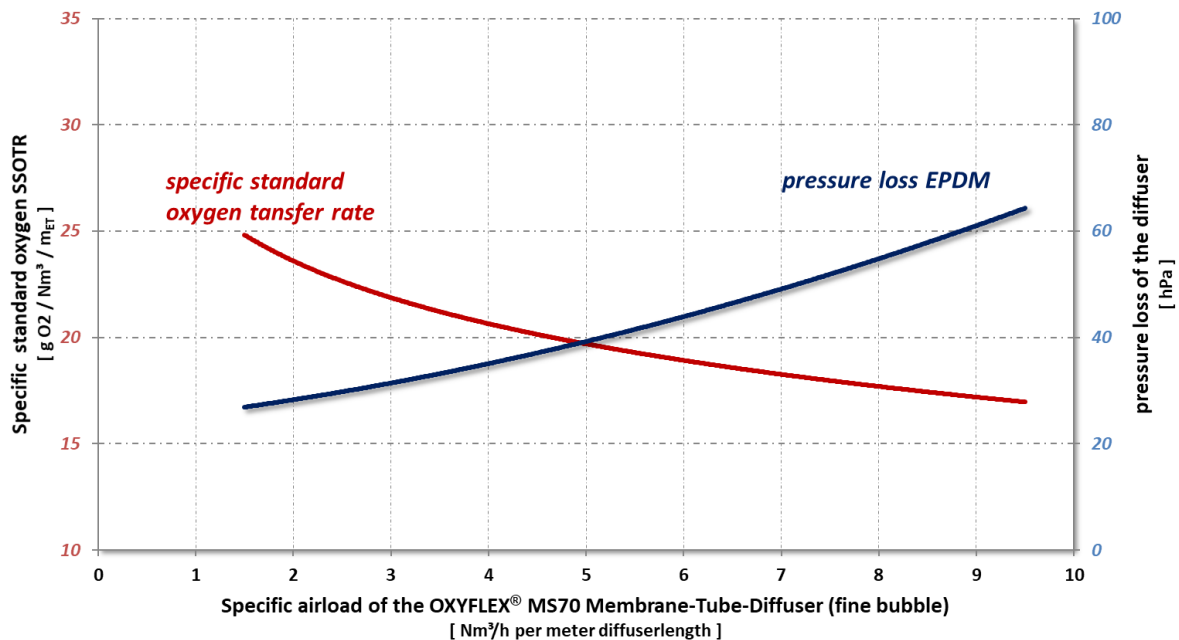

The values are not applicable for other waste water treatment plants! These shown results depend on several influencing factors, such as the tank shape, blow-in depth, coverage or a separate recirculation due to additional mixers.

The diagram can not be used in order to derive warranty claims of any kind.

Supratec will be pleased to prepare a technical data sheet for each individual application for you on request.

AIR-PULSING: mixing without a mixer

The option of the intermittent operating mode means that, in a combined tank with alternating nitrification and denitrification phases and for a sufficient coverage by membrane diffusers, the use of a mixer may not be necessary with OXYFLEX® - Membrane-Diffusers ("Air-Pulsing" process).

Any sedimentation of the activated sludge during the denitrification phase is prevented by short-term aeration intervals. The required aeration intervals are individually adapted to the respective plant with regard to its specific conditions such as the sludge index of the waste water, individualized and the process is repeated approximately every 10 to 20 minutes depending on the plant type.

Mounting instructions

The distance between the diffusers at distribution pipe (axis drilling hole) should be maximal 1.000 mm.

(deviations from that are possible, but they have to be clarified with Supratec)

Considering an installation close to mechanical mixers additional side fixations are recommended for better stability, by this an area-wide coverage can be realized without larger empty areas independent from the mounting type on round or square pipes.

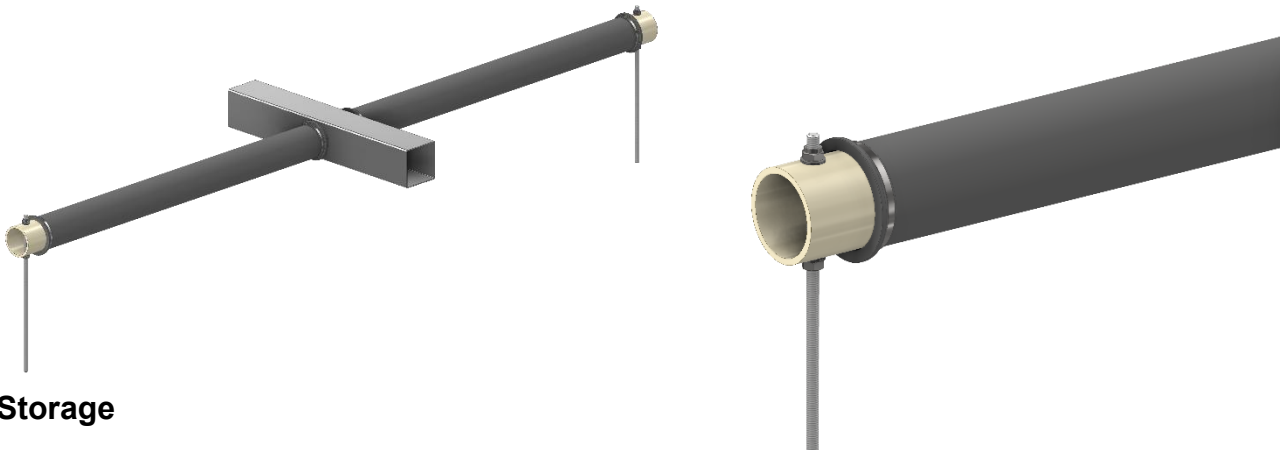

Storage

The diffusers have to be stored in their packaging in a dry, ventilated room. The DIN 7716 has to be considered.

Preparation

Prior to installing the Membrane-Tube-Diffuser OXYFLEX® - MS70 it must be ensured that the pipelines are clean. All drilling chippings, dirt, etc. must be removed, otherwise they will be carried into the diffuser when the fan is started up and could cause significant impairment or damage.

Leveling

Membrane-Tube-Diffusers OXYFLEX® - MS70 can be mounted on several different distribution pipes. The pipe system has to be leveled with ± 10 mm.

For installation on round pipes with Supratec supporters, the pipe clamps must be tightened with torque of 10 Nm (M10); 20 Nm (M12). The surface pressure that this produces ensures that installation is distortion-free. Threads have to be lubricated before screwing the nuts to avoid seizing.

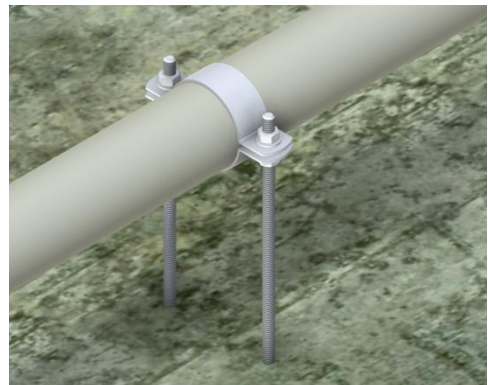

Mounting on square pipes by double nipples

The OXYFLEX® - MS70 can be mounted at square pipes by double nipples with lateral drilling holes. Before screwing the diffusers in it has to be observed that an EPDM gasket is used between the diffusers and distribution pipe. The surfaces have to be clean and straight; the gaskets must sit clean and undamaged between diffusers and pipe.

The short thread of supplied double nipple is to be screwed at first into one diffuser part and can then be stuck through the later holes of the square pipe. Both diffusers will be screwed together by the double nipple. (45 Nm)

The diffusers has to be seated firmly and horizontally.

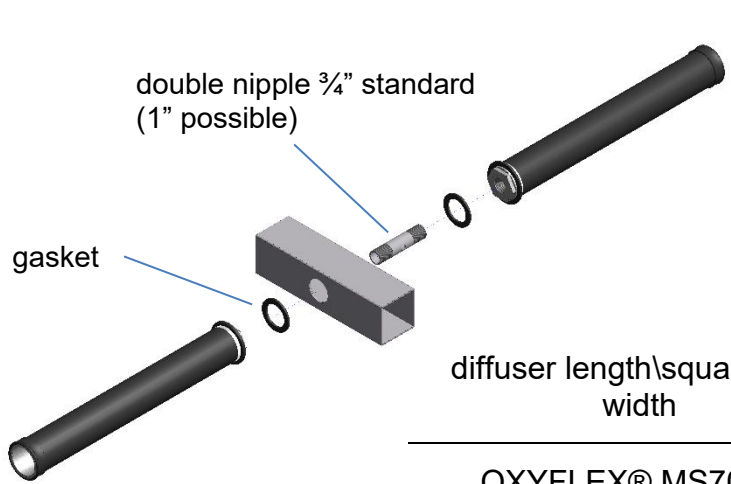

The double nipples are available for standard widths of 80 mm or 100 mm, further widths on request.

diffuser length \ square pipe width	a=80mm	a=100mm
OXYFLEX® MS70-1.0	L=1090mm	L=1110mm
OXYFLEX® MS70-1.5	L=1660mm	L=1680mm
OXYFLEX® MS70-2.0	L=2160mm	L=2180mm

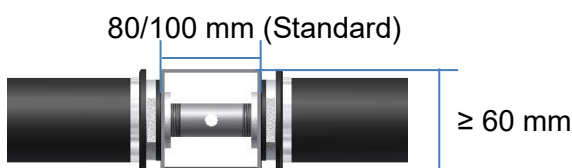
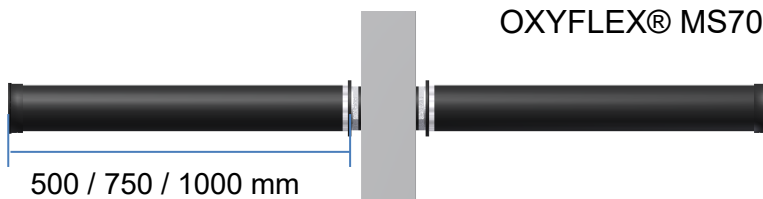

Mounting head with centering:
for standard drilling hole diameter 40 mm
(optional available for Ø 36 mm or Ø 45 mm)

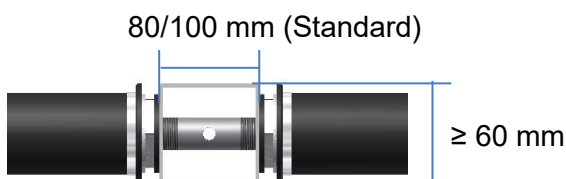

Mounting head without centering:
with drilling hole diameter Ø 27 – Ø 35 mm

Mounting on round pipes by clamp saddles

Membrane-Tube-Diffuser OXYFLEX® - MS70 can be installed on round pipes made out of stainless steel or plastic by clamp saddles. An EPDM O-ring gasket has to be used between each clamp saddles and pipe. The surfaces have to be clean and straight; the gaskets must sit clean and undamaged between diffusers and pipe.

Each mounting head has to be placed centered above the drilled holes $\varnothing = 25$ mm (recommended) of the round pipe. Both pairs of the clamp saddles will be screwed by screws (M8), washers and self-retaining nuts (7 Nm). The screws has to be lubricated before mounting (anti-seize).

The diffusers has to be seated firmly and horizontally.

All screwes has to be screwed in crosswise to prevent jamming!

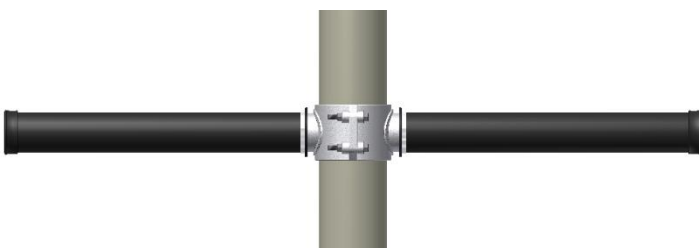
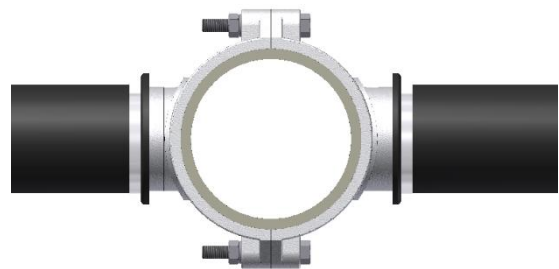
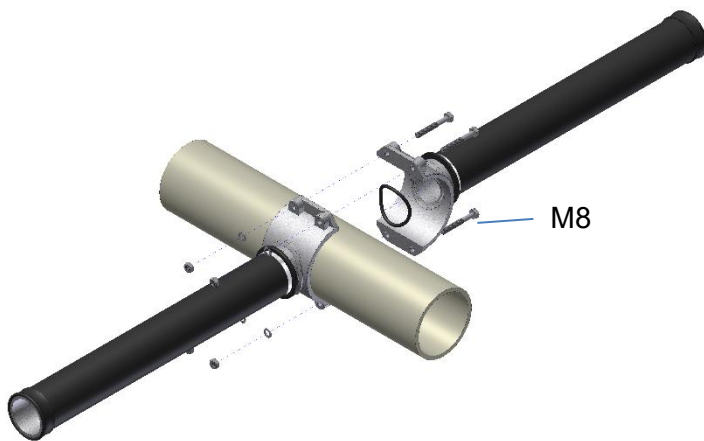

Clamp saddles are available for the following pipe outer diameters:
75 mm (DN65 / 76,1 mm)
90 mm (DN80 / 88,9 mm)
110 mm (DN100 / 114,3 mm)

diffuser length\tube width	d=75mm/ 76,1mm	d=90mm/ 88,9mm	d=110mm/ 114,3mm
OXYFLEX® MS70-1.0	L=1110mm	L=1125mm	L=1145mm
OXYFLEX® MS70-1.5	L=1675mm	L=1690mm	L=1710mm
OXYFLEX® MS70-2.0	L=2175mm	L=2190mm	L=2210mm

Mounting on square pipes by King-Size mounting head

The OXYFLEX® - MS70 can be mounted on square pipes with a drilling hole Ø32mm (larger bore diameter are possible with additional gasket) and stud bolts at the top of the distribution pipe by King-Size mounting head. Before mounting the diffuser there need to be an EPDM gasket between the diffuser and distribution pipe. The surfaces have to be clean and straight; the gaskets must sit clean and undamaged between diffusers and pipe.

The diffuser will be attached from topside onto the distribution pipe and mounted on the stud bolts by washers and self-retaining nuts M6 (4 Nm). The stud bolts have to be lubricated before mounting (anti-seize).

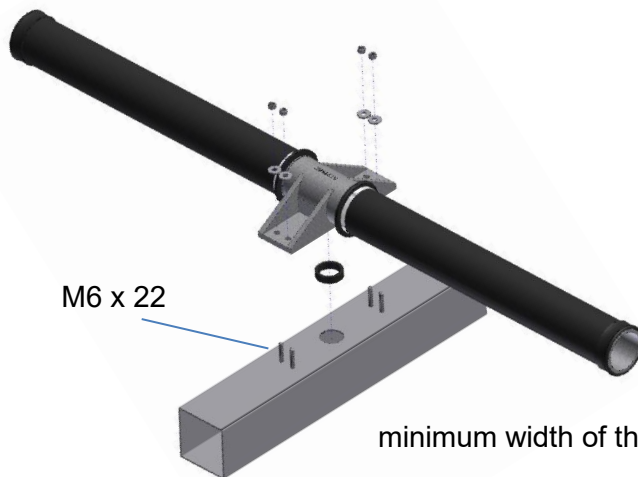

diffuser length\tube width

OXYFLEX® MS70-1.0	L=1100mm
OXYFLEX® MS70-1.5	L=1660mm
OXYFLEX® MS70-2.0	L=2160mm

minimum width of the pipe: 60 mm

Direct installation with male thread

The OXYFLEX® - MS70 can be mounted directly by using mounting head with 1" male thread into existing 1" female threaded nozzles. (8 Nm)

EPDM gasket has to be used between the diffuser and distribution pipe. The surfaces have to be clean and straight; the gaskets must sit clean and undamaged between diffusers and pipe.

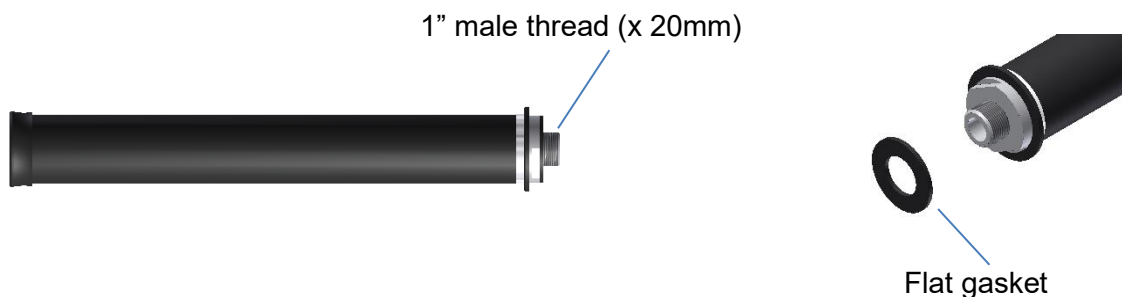

OPERATING INSTRUCTIONS

Functional check and leakage check

After OXYFLEX® - MS70 Membrane-Tube-Diffusers have been installed, a functional and leakage check must be performed. In order to do this, fill the tank up to a level of approx. 10 cm above the top edge of the diffuser with clean water. It is recommended to operate with minimum air amount (see table 1), before the water level reached the aeration grid, in order to avoid water ingress by some bad sealing.

To check the function visually, the diffusers are loaded with the specified amount of air in accordance with the diffuser version (see table 1).

After ensuring that all diffusers are functional, the air quantity is reduced in accordance with the diffuser version (see table 1) in order to make it easier to perform the leakage check. Rising large bubbles indicate leaks (e.g. due to gaskets that have been dislodged) those must be remedied. The successfully performed functional and leakage check must be documented and the water level increased to at least 100 cm above the top edge of the diffuser with clear water as quickly as possible. If immediate commissioning is planned, the tank can also be filled directly with waste water.

Diffuser run-in

The compressed air must not be turned off between the function and leak-tightness check and the run-in of the diffuser. Before normal operation the OXYFLEX® - MS70 Membrane-Tube-Diffusers with EPDM membranes must be operated in clean or waste water continuously (EPDM at least 60 hours / PUR at least 24 hours) with the specified specific load (see table 1) before switching on the automatic operation load.

Deviating procedures are possible in consultation with Supratec.

Bubble pattern

The bubble pattern should be assessed no sooner than when the above-described run-in of the diffusers has been completed. For this purpose the diffusers are operated from the maximum down to the minimum specific load. The evenness of the aeration (bubble pattern test) should be checked when the tank is filled to a level of approx. 100 cm of water above the diffuser top edge. Checking the evenness of the aeration is only possible at a water temperature of above 10°C.

Oxygen transfer test

Prior to carrying out an oxygen transfer test as proof of the efficiency of the OXYFLEX® - MS70 Membrane-Tube-Diffuser model, the above-mentioned steps must have been completed.

The oxygen transfer test can be carried out in accordance with the accepted regulations (e.g. DIN EN 12255-15 : 2003 or DWA-M 209) using the fresh water or waste water method. Specified warranty values must be rigorously adhered to.

A calibrated and exact measurement of the air volume is required.

Commissioning

After successful commissioning, a reference pressure loss measurement enables the evaluation of actual state of aeration system in operation.

If commissioning is delayed and/or system is decommissioned later on, it must be ensured that the diffusers are sufficiently covered by water (at least 100 cm) so that the OXYFLEX® - MS70 Membrane-Tube-Diffusers are protected against strong sun, frost and mechanical damage caused by falling objects, for example.

MAINTENANCE INSTRUCTIONS

The OXYFLEX® - MS70 Membrane-Tube-Diffuser model is a low-maintenance system and is partially self-cleaning due to the different specific air loads during the normal operating cycle. Especially with an intermittent operation mode, the normal operation cycle can be used for parallel maintenance as described below. Depending on the operating conditions we recommend an appropriate maintenance cycle. This maintenance cycle is also used for removing deposits after longer periods of inactivity and long-term operation with low specific loads.

Maintenance cycle

Any deposits are removed by short-term load-dependent changes of the membrane extension. This also prevents any accumulation of biological growth.

- EPDM-Membranen

We recommend daily and no less than weekly maintenance loading in accordance with the diffuser version (see table 1) of approx. 15-30 minutes. Using intermittent operation, the first 10-15 minutes of each aeration cycle are used with the higher maintenance air flow in advance of the standard operation.

- PUR-Membranen

We recommend daily and no less than weekly maintenance loading with a pressure release (lowering the system pressure by about 100mbar) for a minimum time of approx. 5 minutes and a quick start up to the maintenance load in accordance with the diffuser version (see table 1) for a minimum time of approx. 5-10 minutes. Using intermittent operation, at the end of each aeration cycle there need to be a pressure release and minimum for the first 5-10 minutes of each aeration cycle with the higher maintenance air flow in advance of the standard operation.

Monitoring

The bubble pattern and the pressure loss should be checked and documented at regular intervals under similar operating conditions (such as water level and air quantity). The pressure loss development in the load-dependent, seasonal comparison makes it possible to evaluate the condition of the diffuser objectively. In the event of significant changes of the bubble pattern (e.g. partial massive large bubbles instead of homogenous fine bubble pattern) and/or increase of pressure loss of the system (for more than 40 hPa compared to commissioning), Supratec should be consulted immediately. Particularly in the case of systems that are operated intermittently, there is a risk that damaged diffusers can allow the ingress of live sludge into the entire pipework system. This will adversely affect the function and service life of all diffusers.

Cleaning

The condition of the diffusers must be checked whenever the tank is emptied. Particular attention must be paid to soiling (deposits, sludge, coverings etc.), which can usually be easily removed from the membranes. Depending on the type and composition of the soiling, one of the following methods or a combination of several methods might be required. Testing for compatibility and successful results must always be carried out first on individual membranes (particularly with alkalis and acids).

We recommend:

- **Manually:** Cleaning with water and a soft brush is often sufficient for removal of existing deposits. During manual cleaning, a continuous air flow is required. We recommend to operate the diffusers acc. to “functional check” (compare table 1).
- **Alkaline solutions:** Diluted alkaline cleaning agents can usually be used to help with manual cleaning.
- **Acids:** Recognizing pressure increase, dosing of diluted acids in to the compressed air can be required in order to clean the membranes (compare below information)

Acid dosing

In systems in which limescale deposits are to be expected, we recommend that these systems are cleaned with diluted acid ($\leq 85\%$ formic acid for EPDM membranes, respectively $\leq 30\%$ acetic acid for PUR membranes) at regular intervals. If necessary, diluted acid is metered into the compressed air in order to minimise the pressure loss of the membrane and increase the service life of the diffuser. For this purpose, we offer a mobile dosing station for perfectly metered cleaning.

Please contact Supratec for further information about acid dosing.

Table 1: Specific loads [Nm^3/h per meter diffuser] for the OXYFLEX® - MS70 Membrane-Tube-Diffuser with EPDM membrane

Diffuser version	fine bubble	coarse bubble
Functional check	6	10
Diffuser run-in	8	12
Bubble pattern	6	10
Minimum specific load / leakage check	1,0	5,0
Nominal operation range	2 - 8	8 - 13
Maximum continuous load	9	15
Maximum maintenance load	10	17

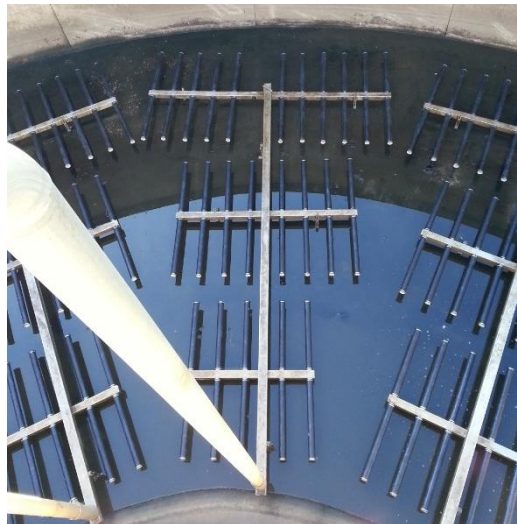

Technical changes reserved.

Possible innovations can be found at our homepage www.oxyflex.de