

OXYFLEX[®] - OM

OVAL-MEMBRANE-TUBE-DIFFUSER

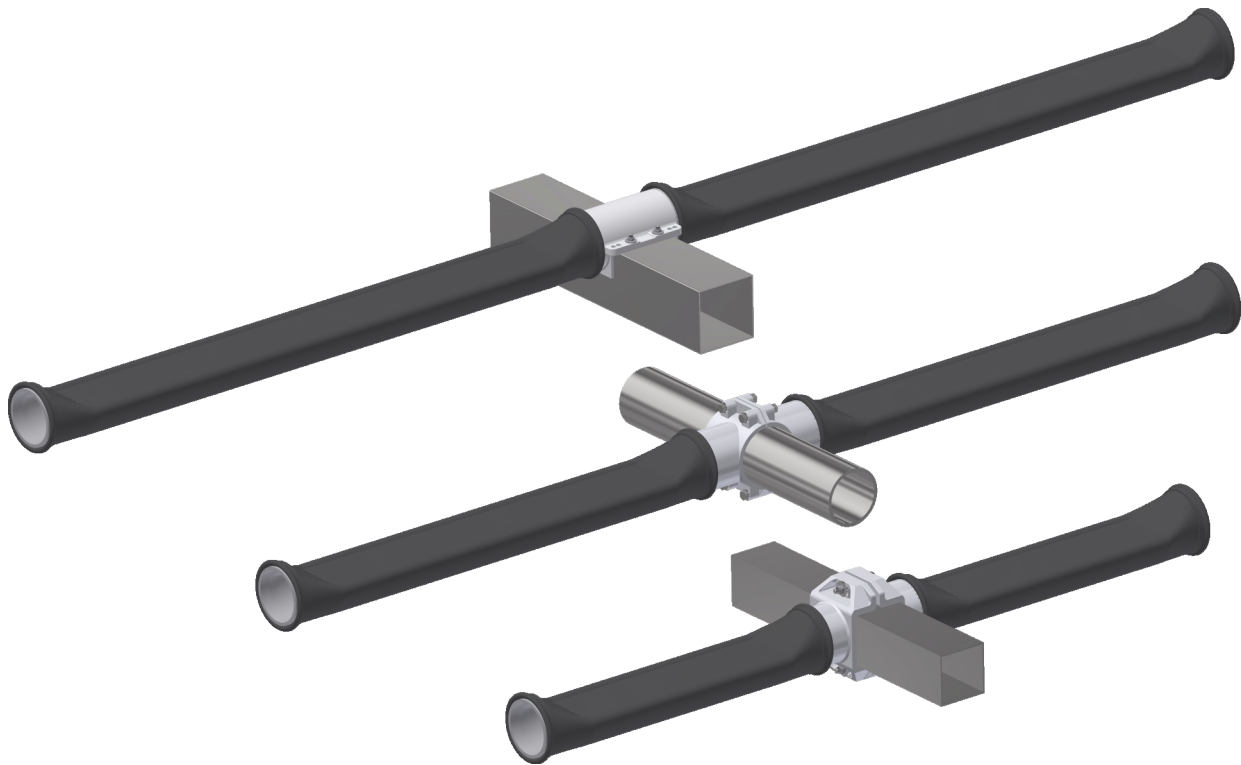

Supratec

GESELLSCHAFT FÜR UMWELT-
UND VERFAHRENSTECHNIK MBH

AERATION TECHNOLOGY



von-Drais-Straße 7
D-55469 Simmern / Hunsrück

Tel.: 06761 / 9 65 09-00
Fax: 06761 / 9 65 09-01

e-mail: info@oxyflex.de
internet: www.oxyflex.de

OXYFLEX®-OM **OVAL-MEMBRANE-TUBE-DIFFUSER**

In comparison to standard round tube diffuser models, the body of OXYFLEX® OM diffuser model is an oval polypropylene tube. By this special design, the oval membrane tube diffuser has a flat membrane area, active only to the top, similar to most efficient plate diffusers. A higher efficiency and significantly longer operation time is resulting by this special shape compared to normal tube diffusers.

The oval membrane tube diffuser OXYFLEX® OM provides the advantages similar to a modern plate diffuser with regard to limited pressure increase and increase efficiency, but enables an availability in different building lengths like standard tube diffusers.

The membrane is slipped over the polypropylene body and is fixed by stainless steel 1-ear clamps at the ends. The high quality membrane (Made in Germany) is available in EPDM.

The body of the OXYFLEX® OM is flooded in the tank to reduce buoyancy.

As a standard, the OXYFLEX® OM is available in 3 lengths:

OXYFLEX® OM 1.0 – with a flat membrane surface of 0,12m² completely active to the top

OXYFLEX® OM 1.5 – with an active flat membrane surface of 0,18m²

OXYFLEX® OM 2.0 – with an active flat membrane surface of 0,24m²

An additional non-return valve is optionally available.

The OXYFLEX® OM oval membrane tube diffuser is characterised by the following superior features:

- ➔ highly more efficient oxygen transfer compared to standard round tube diffuser
- ➔ high operational reliability by limited pressure increase
- ➔ significantly extended operation time
- ➔ possible installation on stainless steel and/or plastic pipes, both round and square pipes
- ➔ available in different lengths
- ➔ insusceptible to fouling

The OXYFLEX® OM oval membrane tube diffuser is able to cover a very broad operating range of up to 30 m³ /h per meter dependent on chosen efficiency and purpose. With the fine-bubble design, specific oxygen transfer rates in pure water of more than 28 g O₂/(m³ x m) can be achieved by an area-covering layout and appropriate water depths.

The diffuser is a highly efficient aeration element, which is predominantly used for the oxygen supply of biological waste water treatment plants.

Of course, OXYFLEX® OM can also be operated in intermittent mode.

As an option to fine-bubble aeration, the membrane can also be manufactured for a coarse-bubble version (up to 40 m³ /h per meter).

For selection of a suitable aeration system, the essential performance is an important criteria besides other technical reasons.

The membranes are perforated individually and specifically for each project in order to achieve the perfect oxygen transfer for all requirements.

The oval membrane tube diffuser OXYFLEX® OM is usually operated between 3 – 12 m_N³/h per meter length. This offers a reasonable compromise between invest-, operation-costs and flow range.

The following diagram shows the example of a result of an oxygen transfer test. The values were measured in a square tank with a water depth of 4.0 m, a diffuser blow-in depth of 3.8 m and coverage of 20%.

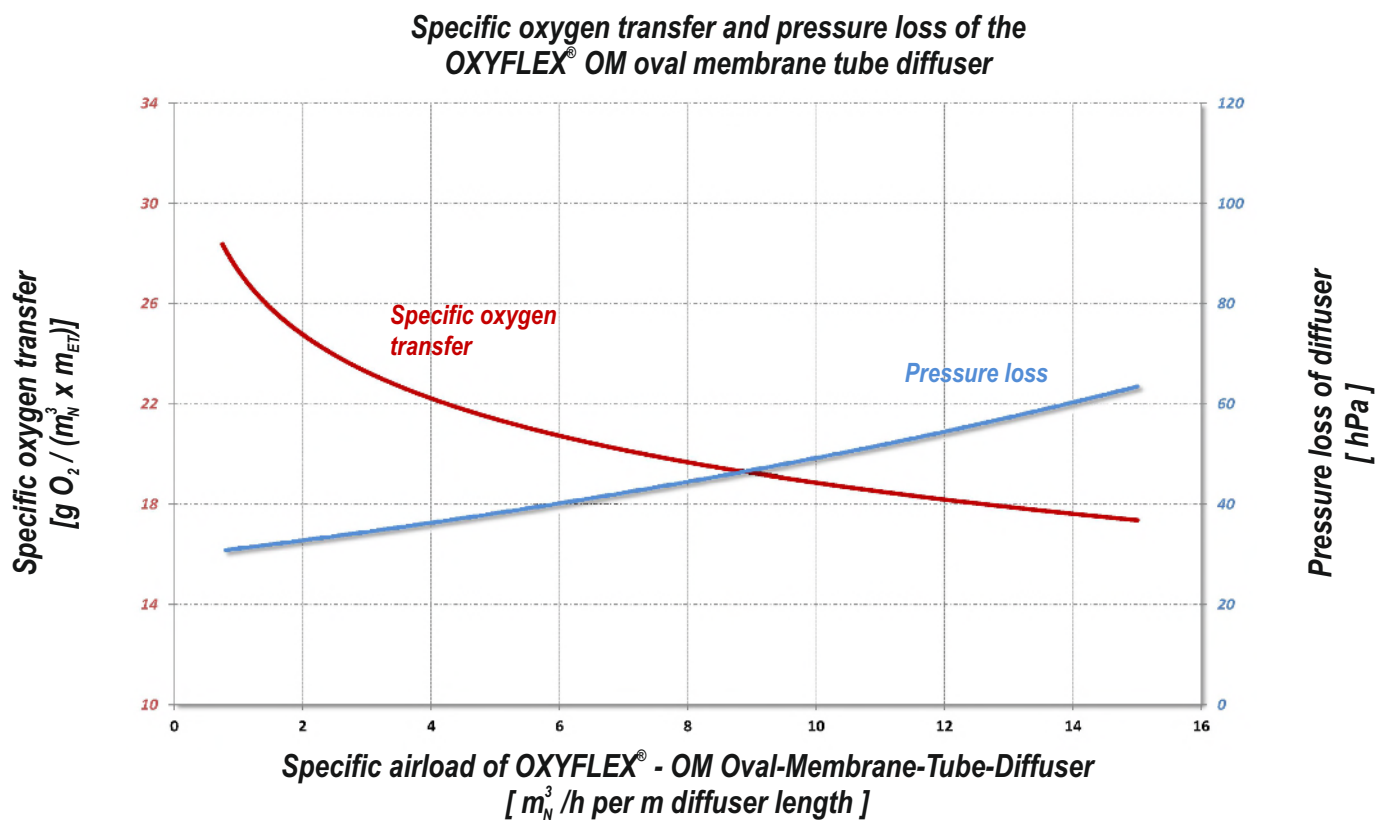

These values cannot be transferred to other plants. The results that are shown here depend on several influencing factors, such as the tank shape, blow-in depth, coverage or a separate recirculation due to additional mixers.

Supratec will be pleased to prepare a technical data sheet for each individual application for you on request.

The diagram cannot be used in order to derive warranty claims of any kind.

AIR-PULSING: mixing without a mixer

The option of the intermittent operating mode means that, in a combined tank with alternating nitrification and denitrification phases and for a sufficient coverage by OXYFLEX® membrane diffusers, the use of a mixer may be not necessary ("Air-Pulsing" process).

Any sedimentation of the activated sludge during the denitrification phase is prevented by short-term aeration intervals. The required aeration intervals are individually adapted to the respective plant with regard to its specific conditions such as the sludge index of the waste water. The aeration time is up to 20 seconds and the process is repeated approximately every 10 to 20 minutes depending on the plant type.

MAINTENANCE

The OXYFLEX® OM oval membrane tube diffuser is a low-maintenance system and is partially self-cleaning due to the different specific air loads during the normal operating cycle. Any deposits are removed by short-term load-dependent changes of the membrane extension. This also prevents any accumulation of biological growth. If the normal operating mode is insufficient for cleaning, we recommend that an additional maintenance cycle is introduced at regular intervals. This maintenance cycle depends on the project and can either include a short-term maintenance load or short-term pressure relief with subsequent quick restart up to full-load operation.

This maintenance cycle is also used for removing deposits after longer periods of inactivity and long-term operation with low specific loads.

MONITORING

The bubble pattern and the pressure loss should be checked and documented at regular intervals under similar operating conditions (such as water level and air quantity). The pressure loss development in the load-dependent, seasonal comparison makes it possible to evaluate the condition of the container objectively.

ACID DOSING

For plants, for which limescale deposits are to be expected, we recommend that these plants are cleaned with diluted acid (85% formic acid for EPDM membranes) at regular intervals. The diluted acid is dosed into the compressed air if required. Our experience shows that these activities will reduce the membranes' pressure loss and extend their service life. For this purpose, we offer a dosing station for perfectly dosed cleaning.

Please contact Supratec for further information about acid dosing.

Variety of installation options

The OXYFLEX® OM oval membrane tube diffuser is suitable for installation on stainless steel pipes and plastic pipes and can therefore be used easily for all existing and new plants. (Clamp saddles and adapters are available for different pipe dimensions.)

Due to the large variety of installation options for round and square pipes, the OXYFLEX® OM oval membrane tube diffuser allows also the easy upgrading and efficiency increase of existing aeration systems while maintaining existing pipelines and minimising costs.

Illustration

Materials:

Diffuser body:	Polypropylene (PP)
Membrane:	EPDM
Seals:	EPDM
1-ear clip:	AISI304 (Standard)

Installation on square pipes with stud bolts

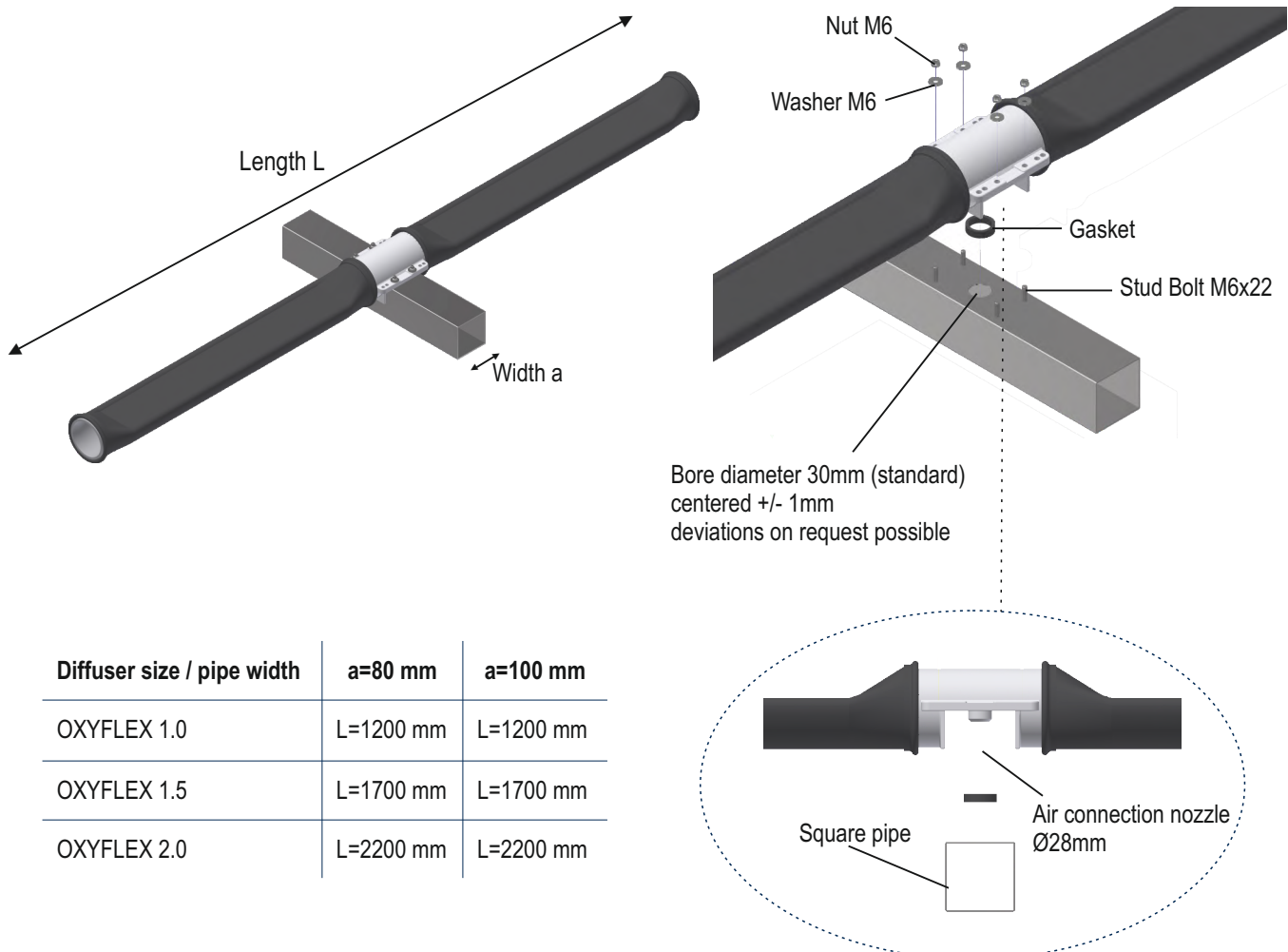

Diffuser size / pipe width	a=80 mm	a=100 mm
OXYFLEX 1.0	L=1200 mm	L=1200 mm
OXYFLEX 1.5	L=1700 mm	L=1700 mm
OXYFLEX 2.0	L=2200 mm	L=2200 mm

Installation on square pipes with U-Bolts

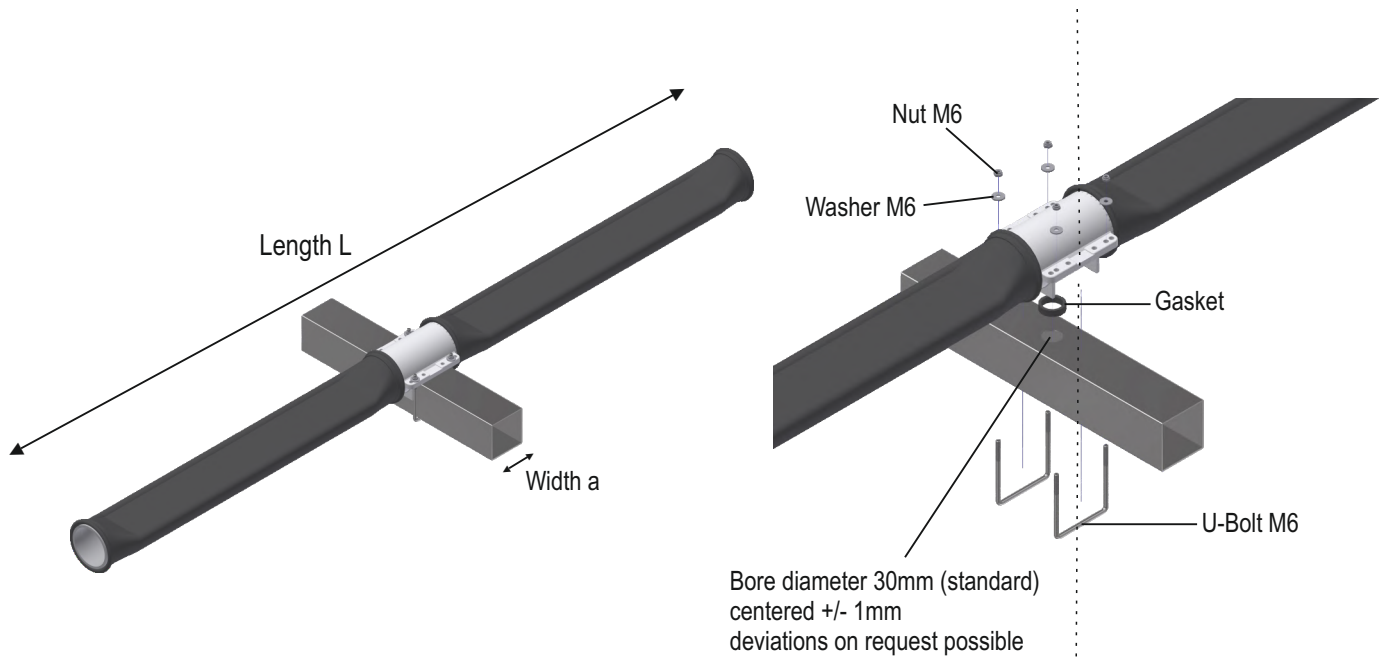

Diffuser size / pipe width	a=80 mm	a=100 mm
OXYFLEX 1.0	L=1200 mm	L=1200 mm
OXYFLEX 1.5	L=1700 mm	L=1700 mm
OXYFLEX 2.0	L=2200 mm	L=2200 mm

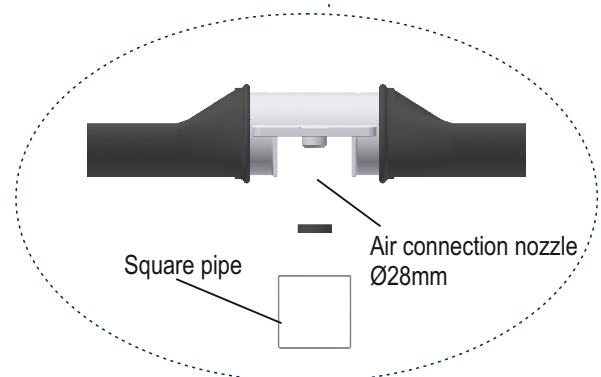

Installation with additional side brackets near the mixer

The optional side brackets allow an area-wide coverage irrespective of the installation type (round or square distribution pipe) near the mixer.



Installation on square pipes with clamp saddle

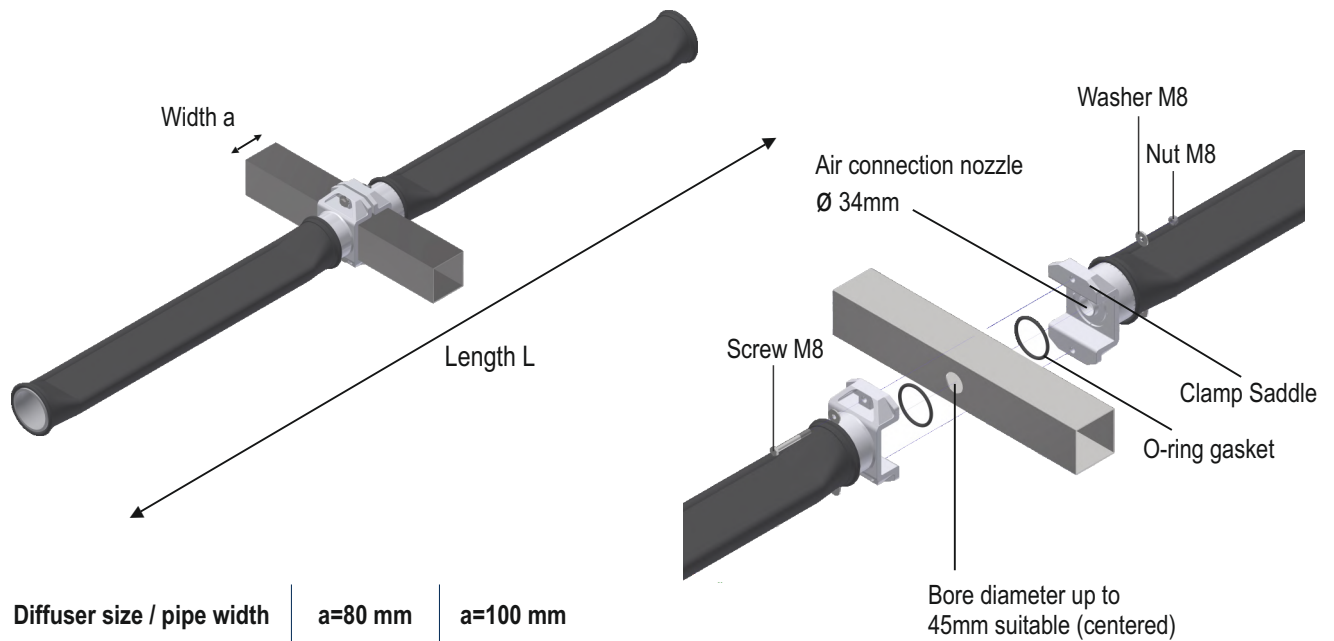

Diffuser size / pipe width	a=80 mm	a=100 mm
OXYFLEX 1.0	L=1230 mm	L=1250 mm
OXYFLEX 1.5	L=1730 mm	L=1750 mm
OXYFLEX 2.0	L=2230 mm	L=2250 mm

Installation on round pipes with clamp saddle

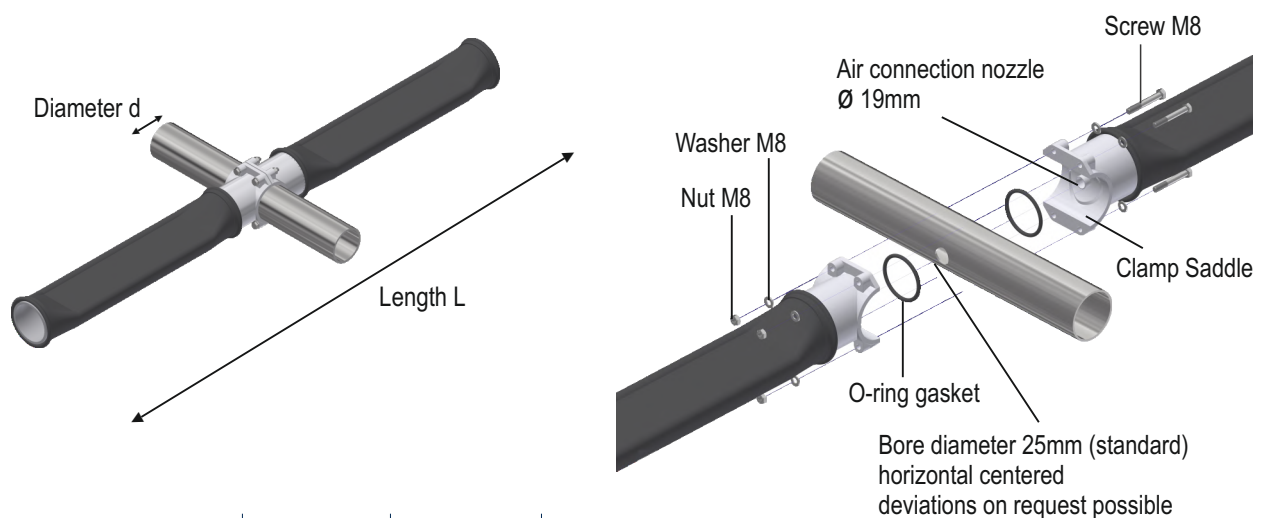

Diffuser size / pipe Ø	d=75 mm/ 76,1 mm	d=90 mm/ 88,9 mm	d=110 mm/ 114,3 mm
OXYFLEX 1.0	L=1236 mm	L=1252 mm	L=1270 mm
OXYFLEX 1.5	L=1736 mm	L=1752 mm	L=1770 mm
OXYFLEX 2.0	L=2236 mm	L=2252 mm	L=2270 mm

GENERAL INFORMATION

Supratec Gesellschaft für Umwelt- und Verfahrenstechnik mbH has more than 45 years of experience with aeration technology and manufactures state-of-the-art, highly efficient aeration systems. These products are predominantly used for providing the oxygen supply for biological waste water treatment processes but can also be used for the aeration of liquids of all kinds.

Possible areas of application for Supratec diffusers are:

- ➔ communal waste water treatment plants
- ➔ industrial waste water treatment plants
- ➔ special technical processes such as "stripping" of gases, etc.

We have the competence and wealth of experience in order to consult and support you with the planning, implementation and operation of your projects.

On request we gladly send you a reference list.

We will also like to carry out the installation of our products for you if required.



For further notes and special information please see the installation, operating and maintenance instructions.