

# OXYFLEX® - MS96 Membrane-Tube-Diffuser

for fine bubble and coarse bubble diffusion of liquids

## INSTALLATION, OPERATING and MAINTENANCE INSTRUCTIONS

OXYFLEX® - MS96-Membrane-Tube-Diffuser type has a solid, strong tube body (Ø90mm) made of polypropylene (PP). The membranes are slipped over the body and each is fixed by two stainless steel 1-ear clamps (standard material AISI 304).

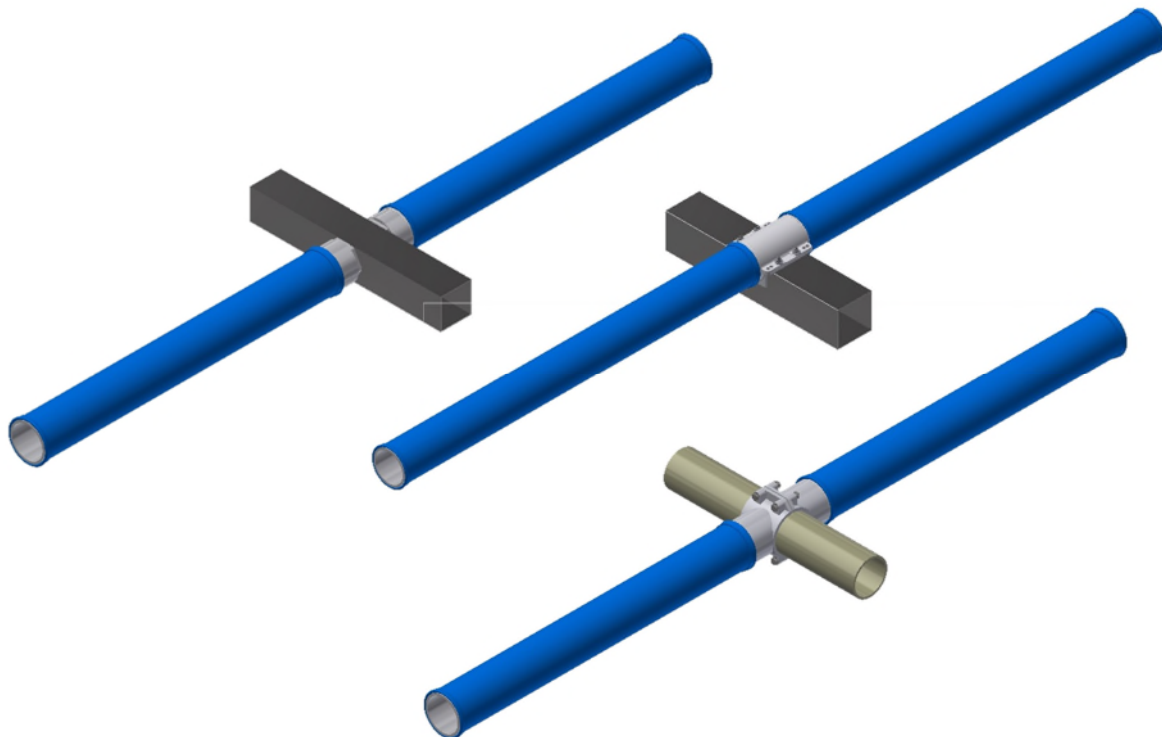

## INSTALLATION INSTRUCTIONS

The distance between the diffusers on the distribution pipe (connection hole axis) should be at least 180 mm and must not exceed 1,000 mm (differences possible on request).

In the vicinity of the mixer, optional side brackets provide additional stability and make area-wide coverage possible in this case as well (independently of the type of installation on round or square distribution pipes).

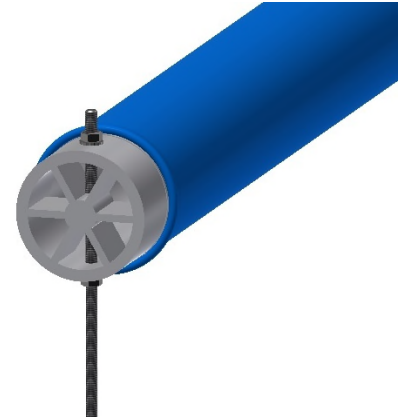

### Storage

Store the diffusers in their packaging in a dry and ventilated room. DIN 7716 provisions must be observed.

### Preparation

Prior to installing the OXYFLEX® - MS96-Membrane-Tube-Diffuser it must be ensured that the pipelines are clean. All drilling chippings, dirt, etc. must be removed, otherwise they will be carried into the diffuser when the fan is started up and could cause significant impairment or damage.

### Levelling

The OXYFLEX® - MS96-Membrane-Tube-Diffuser is mounted onto distribution pipes (round or square pipe depending on version). The distribution pipes must be levelled to a maximum of  $\pm 10$  mm.

## Installation on square pipes by welded thread bolts

The distance between the bolts is 112 x 50 mm (see sketch). We would be pleased to provide you with an appropriate welding template.

An EPDM gasket is inserted between the diffuser and the distribution pipe. The surfaces must be clean and straight. Gasket must sit clean and undamaged between the diffuser and the pipe.

The air-socket  $\varnothing = 28$  mm is inserted from above into the bore hole  $\varnothing = 30$  mm of the square pipe. The diffuser is fixed by using the threaded bolts M6 x 22 mm with washers and self-locking nuts M6 (4 Nm). The threaded bolts must be lubricated beforehand to avoid seizing.

Always make sure that the diffuser is firmly and horizontally seated.

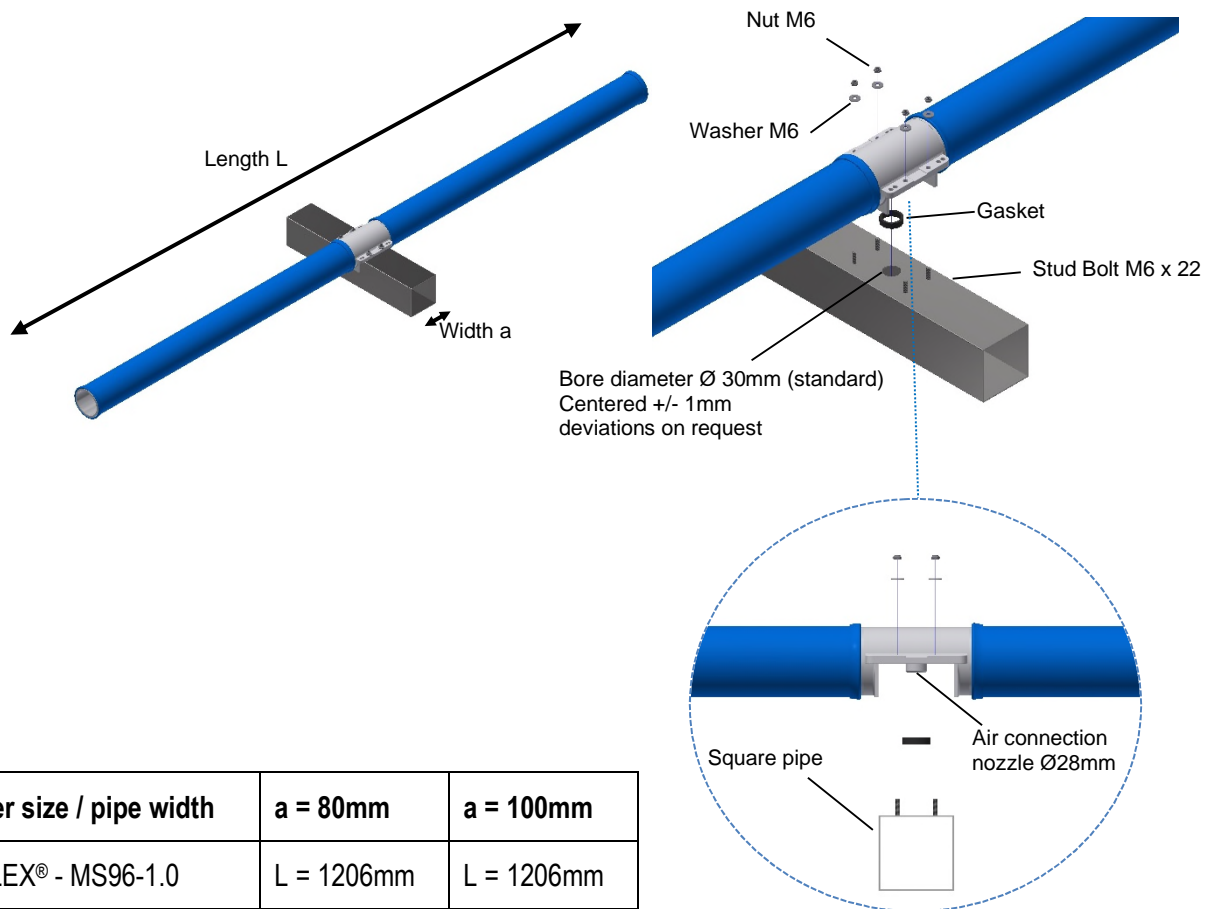

Diffuser size / pipe width	a = 80mm	a = 100mm
OXYFLEX® - MS96-1.0	L = 1206mm	L = 1206mm
OXYFLEX® - MS96-1.5	L = 1706mm	L = 1706mm
OXYFLEX® - MS96-2.0	L = 2206mm	L = 2206mm

Possible pipe dimensions:

Width: 80 mm or 100 mm

(Further sizes are available on request)

## Installation on square pipes by U-bolts

An EPDM gasket is inserted between the diffuser and the distribution pipe. The surfaces must be clean and straight. Gasket must sit clean and undamaged between the diffuser and the pipe.

The air-socket  $\varnothing = 28 \text{ mm}$  is inserted from above into the bore hole  $\varnothing = 30 \text{ mm}$  of the square pipe. The U-bolts M6 are put around the square pipe from below and insert through the holes of the installation head of the diffuser. By using washers and self-locking nuts M6 the diffuser is fixed by crosswise screwing (4 Nm). The threads of the U-bolts must be lubricated beforehand to avoid seizing.

Always make sure that the diffuser is firmly and horizontally assembled.

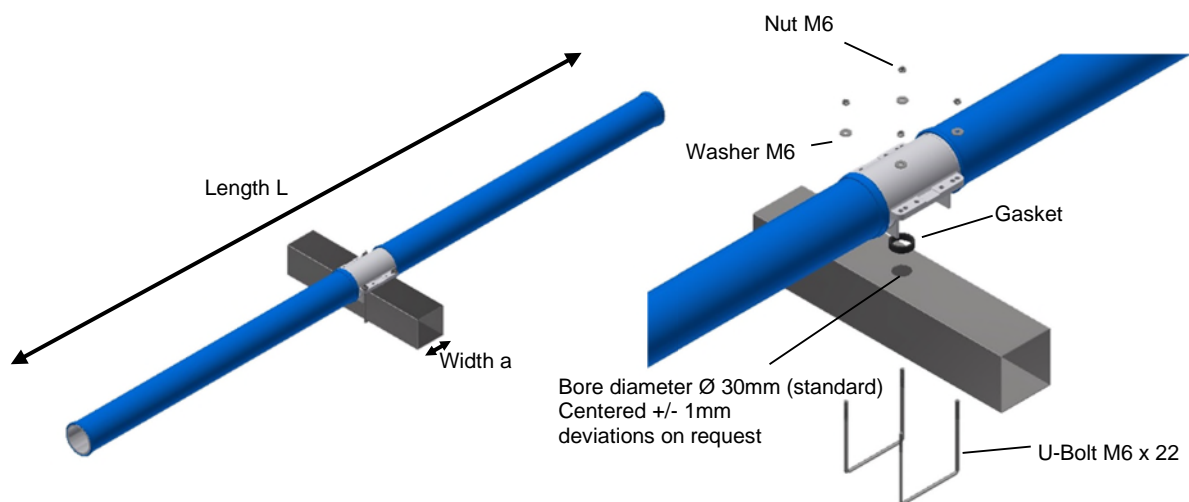

Diffuser size / pipe width	a = 80mm	a = 100mm
OXYFLEX® - MS96-1.0	L = 1206mm	L = 1206mm
OXYFLEX® - MS96-1.5	L = 1706mm	L = 1706mm
OXYFLEX® - MS96-2.0	L = 2206mm	L = 2206mm

Possible pipe dimensions:

80x80 mm/ 100x100 mm

(Further sizes are available on request)

## Installation on round pipes

The OXYFLEX® - MS96-Membrane-Tube-Diffuser is attached to round pipe made from stainless steel or plastic using a clamp saddle.

An O-ring gasket (EPDM) is inserted between the diffuser and the distribution pipe. The surfaces must be clean and straight. Gasket must sit clean and undamaged between the diffuser and the pipe. The air-socket  $\varnothing = 19$  mm of each diffuser side is inserted into the lateral bore holes  $\varnothing = 25$ mm (recommended diameter) of the round pipe. Both diffuser parts are screwed together by using M8 x 60 mm hexagon screws, washers and self-locking nuts (7 Nm). The threads of the hexagon screws must be lubricated beforehand to avoid seizing.

Always make sure that the diffuser is firmly and horizontally assembled.

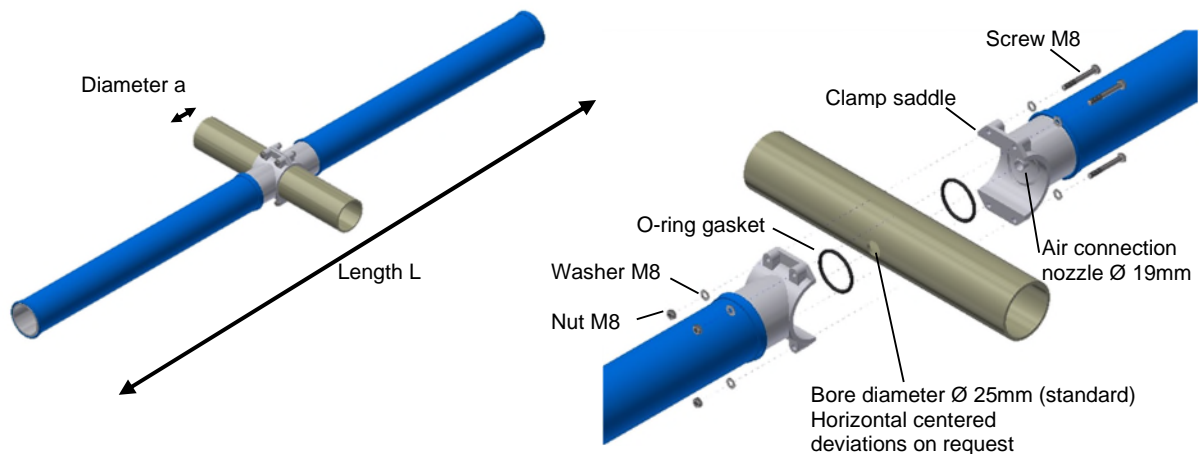

Diffuser size / pipe width	D = 75mm / 76,1mm	D = 90mm / 88,9mm	D = 110mm / 114,3mm
OXYFLEX® - MS96-1.0	L = 1242mm	L = 1258mm	L = 1276mm
OXYFLEX® - MS96-1.5	L = 1742mm	L = 1758mm	L = 1776mm
OXYFLEX® - MS96-2.0	L = 2242mm	L = 2258mm	L = 2276mm

Possible pipe dimensions:

for stainless steel pipes:

DN 65 (76,1mm) / DN 80 (88,9mm) / DN 100 (114,3mm)

for plastic pipes (outer- $\varnothing$ ):

75 mm / 90 mm / 110 mm

(Further sizes are available on request)

All Screwings must be tightend uniformly and crosswise in order to avoid tilting!

## **OPERATING INSTRUCTIONS**

### Functional check and leakage check

After OXYFLEX® - MS96-Membrane-Tube-Diffusers has been installed, a functional and leakage check must be performed. In order to do this, fill the tank up to a level of approx. 10 cm above the top edge of the diffuser with clean water. It is recommended to operate with minimum air amount (see table 1 on page 8), before the water level reached the aeration grid, in order to avoid water ingress by some bad sealing.

To check the function visually, the diffusers are loaded with the specified amount of air in accordance with the diffuser version (see table 1 on page 8).

After ensuring that all diffusers are functional, the air quantity is reduced in accordance with the diffuser version (see table 1 on page 8) in order to make it easier to perform the leakage check. Rising large bubbles indicate leaks (e.g. due to gaskets that have been dislodged) those must be remedied.

The successfully performed functional and leakage check must be documented and the water level increased to at least 100 cm above the top edge of the diffuser as quickly as possible.

### Diffuser run-in

The compressed air must not be turned off between the function and leak-tightness check and the run-in of the diffuser. OXYFLEX® - MS96-Membrane-Tube-Diffusers with EPDM membranes must be operated continuously for at least 60 hours with the specified specific load (see run-in of diffusers in table 1 on page 8).

Deviating procedures are possible in consultation with Supratec.

### Bubble pattern

The bubble pattern should be assessed no sooner than when the above-described run-in of the diffusers has been completed. For this purpose the diffusers are operated from the maximum down to the minimum specific load.

The evenness of the aeration (bubble pattern test) should be checked when the tank is filled to a level of approx. 100 cm of water above the diffuser top edge.

Checking the evenness of the aeration is only possible at a water temperature of above 10°C.

### Oxygen transfer test

Prior to carrying out an oxygen transfer test as proof of the efficiency of the OXYFLEX® - MS96-Membrane-Tube-Diffuser model, the above-mentioned steps must have been completed.

The oxygen transfer test can be carried out in accordance with the accepted regulations (e.g. DIN EN 12255-15 : 2003 or DWA-M 209) using the fresh water or waste water method. Specified warranty values must be rigorously adhered to. A calibrated and exact measurement of the air volume is required.

### Commissioning

If commissioning is delayed and/or system is decommissioned later on, it must be ensured that the diffusers are sufficiently covered by water (at least 100 cm) so that the OXYFLEX® - MS96-Membrane-Tube-Diffusers are protected against strong sun, frost and mechanical damage caused by falling objects, for example.

After successful commissioning, a reference pressure loss measurement enables the evaluation of actual state of aeration system in operation.

## MAINTENANCE INSTRUCTIONS

The OXYFLEX® - MS96-Membrane-Tube-Diffuser model is a low-maintenance system and is partially self-cleaning due to the different specific air loads during the normal operating cycle. Especially with an intermittent operation mode, the normal operation cycle can be used for parallel maintenance as described below. Depending on the operating conditions we recommend an appropriate maintenance cycle. This maintenance cycle is also used for removing deposits after longer periods of inactivity and long-term operation with low specific loads.

### Maintenance cycle

Any deposits are removed by short-term load-dependent changes of the membrane extension. This also prevents any accumulation of biological growth.

Using OXYFLEX® - MS96-Membrane-Tube-Diffusers with EPDM membranes, we recommend daily and no less than weekly maintenance loading in accordance with the diffuser version (see table 1 on page 8) of approx. 15-30 minutes. Using intermittent operation, the first 10-15 minutes of each aeration cycle are used with the higher maintenance air flow in advance of standard operation.

Deviating procedures are possible in consultation with Supratec.

### Monitoring

The bubble pattern and the pressure loss should be checked and documented at regular intervals under similar operating conditions (such as water level and air quantity). The pressure loss development in the load-dependent, seasonal comparison makes it possible to evaluate the condition of the container objectively.

In the event of significant changes of the bubble pattern (e.g. partial massive large bubbles instead of homogenous fine bubble pattern) and/or increase of pressure loss of the system (for more than 40 hPa compared to commissioning), Supratec should be consulted immediately. Particularly in the case of systems that are operated intermittently, there is a risk that damaged diffusers can allow the ingress of live sludge into the entire pipework system. This will adversely affect the function and service life of all diffusers.

### Cleaning

The condition of the diffusers must be checked whenever the tank is emptied. Particular attention must be paid to soiling (deposits, sludge, coverings etc.), which can usually be easily removed from the membranes. Depending on the type and composition of the soiling, one of the following methods or a combination of several methods might be required. Testing for compatibility and successful results must always be carried out first on individual membranes (particularly with alkalis and acids). We recommend:

- Manually: Cleaning with water and a soft brush is often sufficient for removal of existing deposits
- Alkaline solutions: Diluted alkaline cleaning agents can usually be used to help with manual cleaning.
- Acids: Recognizing pressure increase, dosing of diluted acids in to the compressed air can be required in order to clean the membranes (compare below information)

### Acid dosing

In systems in which limescale deposits are to be expected, we recommend that these systems are cleaned with diluted acid ( $\leq 85\%$  formic acid for EPDM membranes) at regular intervals. If necessary, diluted acid is metered into the compressed air in order to minimise the pressure loss of the membrane and increase the service life of the diffuser. For this purpose, we offer a mobile dosing station for perfectly metered cleaning.

Please contact Supratec for further information about acid dosing.

## Repair measures

Our more than 30 years of experience have shown that the OXYFLEX® -Membrane-Diffusers are an extremely robust and reliable diffusertype. If a diffuser element is damaged nevertheless, a diver can be deployed to remedy the problem without having to empty the tank. The diver can remove the damaged diffuser underwater and close off the relevant bore hole. Depending on the diffuser system that is installed, several bore holes can often be closed off without having a major effect on oxygen transfer. The replacement of individual diffusers on an existing grating is not recommended, since new membranes differ considerably from older membranes with regard to pressure loss. We would be pleased to provide advice if necessary.

**Table 1:** Specific loads [ $m^3_N/h$  per m diffuser] for OXYFLEX® - MS96-Membrane-Tube-Diffuser model with EPDM Membrane

Functional check	8
Diffuser run-in	8
Bubble pattern (starting with higher specific load)	12 - 2
Minimum specific load / leakage check	1
Nominal operating range	2 - 12
Maximum continuous load	14
Maximum short-term specific load / maintenance load	20

**We reserve the right to make technical alterations.**

**For current version please check our website [www.oxyflex.de](http://www.oxyflex.de)**

